

Smooth wash  
of light free  
of hot spots  
and socket  
shadows

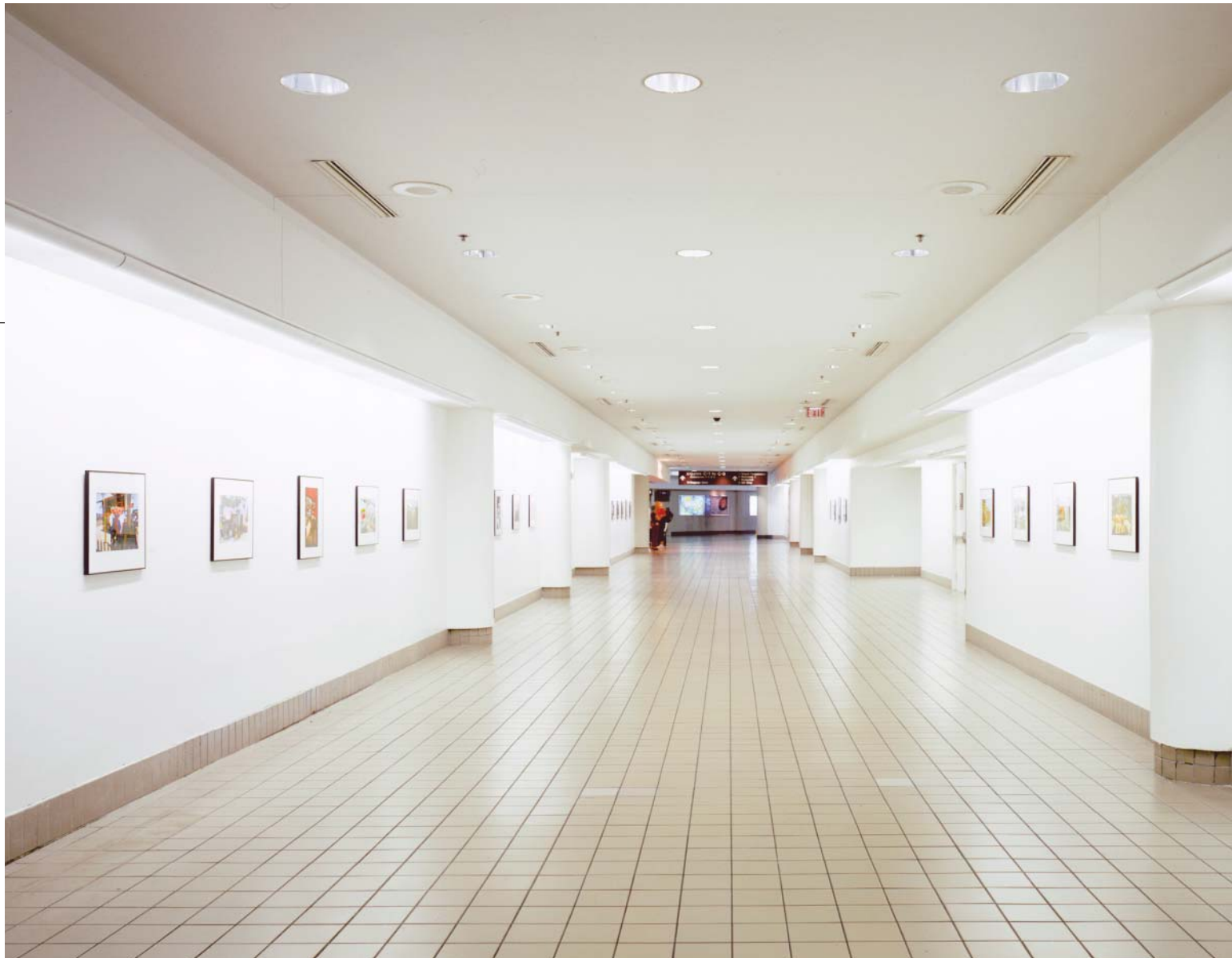

**Lighting Design:**

Elaine Morris, Designlight

**Photography:**

Michael Lewis

**Concourse Art Walls**

Space: Approx. 19' wide, 13'-6" ceiling with 11' high walls (below soffit)

Lighting: 232 linear feet of F144 with 4' 28W T5 lamps; 18" setback from wall

Estimated average initial illuminance on wall: 32 fc, max : min < 7.3 : 1

Estimated average initial illuminance at floor: 14 fc (wall lighting only)

Estimated power density (typical bays): 0.56 watts per sq. ft. (wall lighting only)

The challenge... lighting art walls in an existing airport concourse with limited setback and no space to recess.

The solution... the low profile **Style F144** lights the entire wall evenly and is simple and economical to install.



Polycarbonate gray radial baffles appear white when lighted and blend into housing.



Footcandles initial - T5 lamp (excludes downlights)

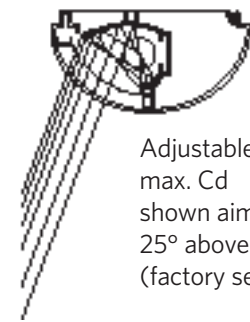
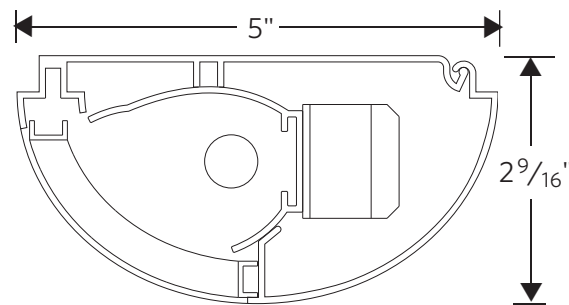

Adjustable - max. Cd shown aimed 25° above nadir (factory setting)